

### INSTALLATION INSTRUCTIONS

The DU3 is a vehicle detector unit with self-contained electronics, designed for use with a drive-thru timer system. It should be installed at the service window, not at the menu board or speaker post.

Installation of the DU3 requires only one hole to be drilled through the wall for cable routing, and four screw holes for mounting the detector unit on the outside wall of the building, near the drive-thru service window. Its cables will be routed to the AC adapter and the timer system control unit.

Installation of the DU3 should take approximately one hour. Follow these instructions.

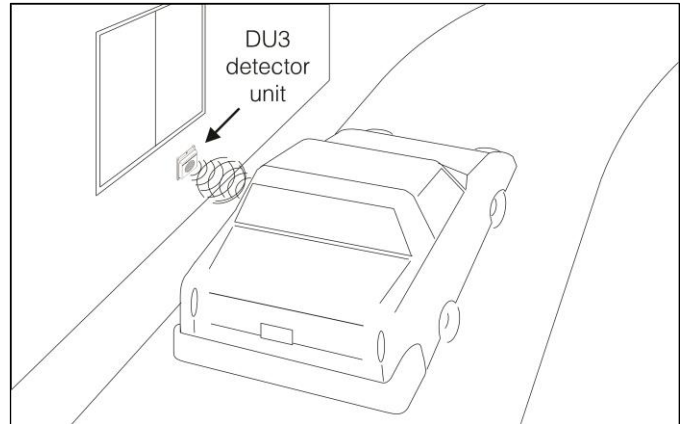

Figure. 1 Typical DU3 installation site

### Parts List

The following parts are included with the DU3. As the items are unpacked, check them against the packing slip. If any item is missing or damaged, contact your HME sales representative.

- Detector unit with 12 ft. (3.66 meter) cables
- AC to DC Adapter
- Mounting hardware

### Tools Required

Be certain you have the items listed below before beginning the DU3 installation.

- Tape measure
- Phillips (cross point) and standard (slotted) screwdrivers
- Electric drill with ½ inch (13mm) and ¼ inch (6mm) bits to drill the mounting surface (wood, cinder block or metal) where detector unit will be installed
- Electrical tape or shrink tubing

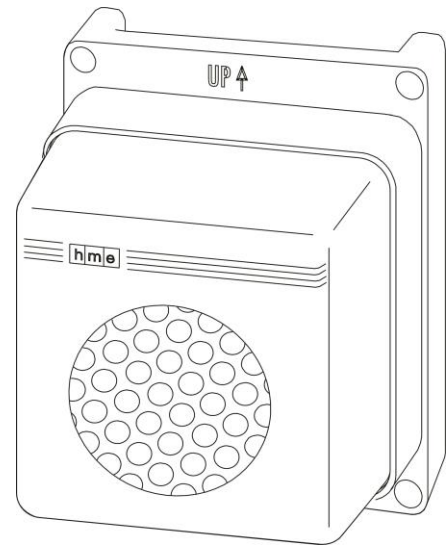
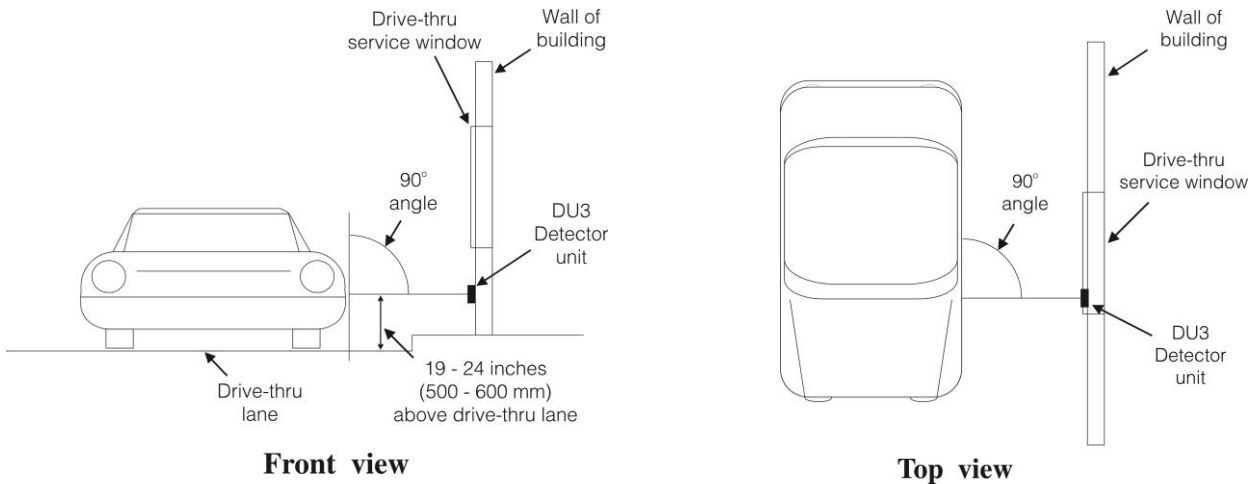

Figure. 2 DU3 detector unit

# 1. Detector unit mounting

Determine where the detector unit will be mounted on the outside wall of the building.  
(See Figure 3.)

**NOTE:** Be certain there is an available AC electrical outlet near the mounting site, on the wall inside the drive-thru service



**Figure. 3**  
**Typical DU3 position on building near drive-thru service window**

- Drill a ½ inch (13mm) hole through the wall at the location where the detector unit will be mounted.
- Hold the unit centered over the hole, against the outside wall, and mark the wall through the four holes at the corners of the unit.
- Drill four ¼ inch (6mm) screw holes at the marked spots, deep enough to insert the enclosed screw anchors.
- Insert the enclosed screw anchors completely into the four screw holes.
- Route the 12 ft. (3.66 meter) cables from the back of the detector unit through the ½ inch (13mm) center hole.
- Hold the detector unit with the arrow on its top-front pointing up (Figure 4), and the screw holes at its four corners over the screw anchors on the wall. Push any slack cable back through the center hole into the building.
- Screw the four enclosed screws through the screw holes in the detector unit (Figure 4) and into the screw anchors, to fasten the unit securely to the outside wall.

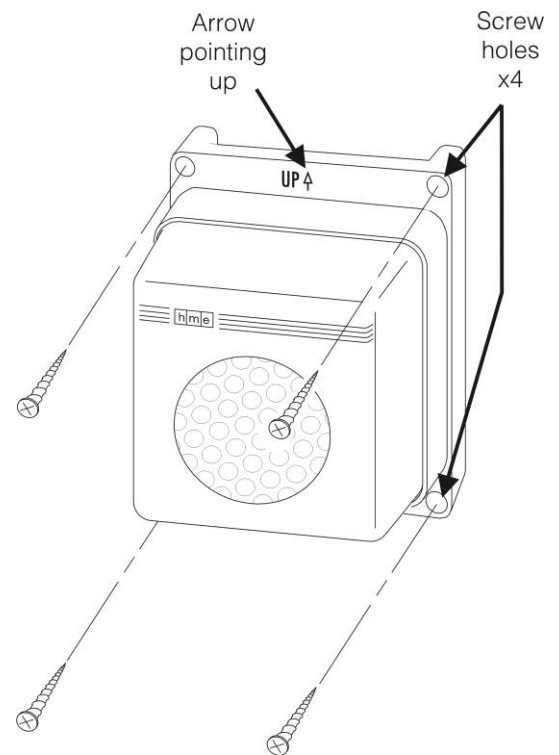

**Figure. 4**  
**Mounting the DU3 detector unit**

## 2. Cable routing and connections

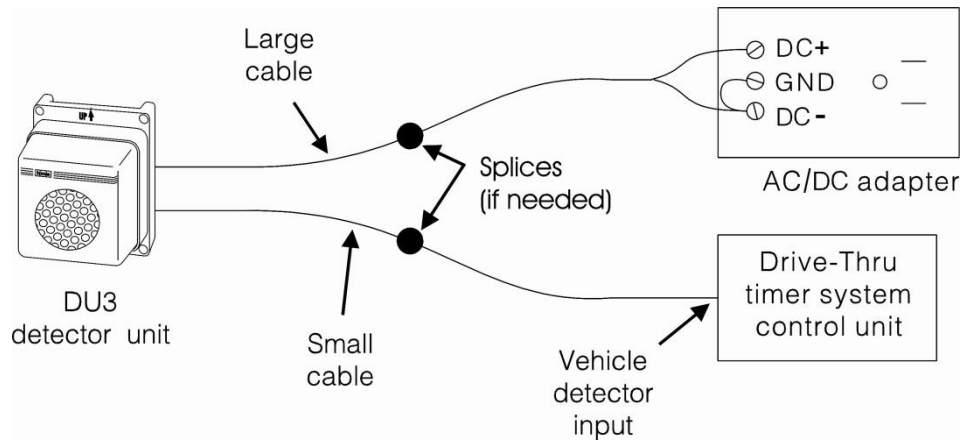

Figure. 5 DU3 cable routing and connections

- Inside the drive-thru service area, route the end of the smaller cable from the detector unit to the control unit of the drive-thru timer system. Connect the cable wires to the vehicle detector input of the control unit. **NOTE:** If the smaller cable from the detector unit is not long enough, up to 188 ft (57 meters) of additional two-conductor (24 AWG) audio cable (or equivalent) can be spliced to it. Cover splices with electrical tape or shrink tubing. Connections are not polarity sensitive.
- Route the larger cable coming through the wall from the DU3 to the AC/DC power adapter. Connect the wires of this cable to the two outer screws on the bottom of the AC/DC adapter, then connect a short 16AWG jumper cable/bridging jumper between “GND” and “DC-“ terminal, as shown in Figure 5. **NOTE:** If the larger cable from the detector unit is not long enough, up to 188 ft (57 meters) of additional two-conductor (16 AWG) cable (or equivalent) can be spliced to it. Cover splices with electrical tape or shrink tubing.
- Plug the adapter into an AC electrical outlet.

**THE DU3 INSTALLATION IS NOW COMPLETE. THE DU3 SHOULD BE OPERATIONAL.**

## 3. DU3 Operational check

- Go outside and listen for a clicking sound from the detector unit. It should click continually, each time it sends out a pulse.
- Have a vehicle driven up to the drive-thru service window. Check to be certain the DU3 has activated the timer system when the vehicle arrived (approximately 2 second delay). Have the vehicle driven away to be certain the timer system is deactivated (approximately ½ second delay).

**NOTE:** The window of detection is factory set to detect an object between 1½ and 7 feet (460 mm - 2.140 meters).

## 4. Troubleshooting and Correcting Problems

<b>TROUBLE SHOOTING CHECKLIST</b>		
<b>Problem</b>	<b>Probable Cause</b>	<b>Solution</b>
No clicking sound is heard from DU3 detector unit	AC/DC adapter is not properly connected	<ol style="list-style-type: none"> <li>1. Be certain larger cable from detector unit is connected to AC adapter.</li> <li>2. Be certain adapter is plugged into AC electrical outlet.</li> <li>3. 3. If clicking sound is still not heard, call HME.</li> </ol>
Clicking sound is heard at DU3 detector unit, but drive-thru timer system is not activated	The timer system or DU3 detector unit may be malfunctioning or the cable from the timer system may be defective.	<ol style="list-style-type: none"> <li>1. Short the connectors at vehicle detector input of timer system control unit (See Figure 5). <ul style="list-style-type: none"> <li>• If vehicle-detect signal is not heard or seen, timer system is defective. Check timer system.</li> <li>• If vehicle-detect signal is heard or seen, timer system is OK. Problem may be with detector unit. Call HME.</li> </ul> </li> <li>2. If cable is spliced, short the timer system cable wires at the splice. (See Figure 5) <ul style="list-style-type: none"> <li>• If vehicle-detect signal is not heard or seen, cable from timer system is defective. Replace cable.</li> <li>• If vehicle-detect signal is heard or seen, detector unit is malfunctioning. Call HME.</li> </ul> </li> </ol>

\* For assistance, call HME Customer Support at 1-800-848-4468

## 5. Specifications

<b>A. DU3 voltage input:</b>	24V DC
<b>B. DC current:</b>	100mA Minimum, 3A Maximum
<b>C. Operating temperature range:</b>	-40°F to 122°F (-40°C to 50°C)
<b>D. Internal Heater:</b>	Active below 50°F (100C)
<b>C. Acoustic Characteristics:</b>	Ultrasonic, Frequency 50kHz
<b>D. Angle of Detection:</b>	Target must be perpendicular $\pm 150$ @ 3 feet (.91 meter).
<b>E. Detection Range:</b>	1 to 7 ( $\pm 1$ ) feet (.30 to 2.13 meter, $\pm .30$ meter)
<b>F. Turn On Delay:</b>	2 ( $\pm .5$ ) seconds
<b>G. Turn Off Delay:</b>	.5 ( $\pm .3$ ) seconds
<b>H. Connectors:</b>	None
<b>I. Controls:</b>	None
<b>J. Indicators:</b>	None
<b>K. Vehicle Detection Output:</b>	Relay Closure (SPST, normally open) Maximum Switching Power, 10VA Maximum Switching Voltage, 100VDC or peak AC Maximum Switching Current, 0.50 A Maximum Carry Current, 1.00 A
<b>L. Cables:</b>	Power Input: 2 conductor (16 AWG) cable 12 feet (3.66 meters) long. Vehicle Detector Output: 2 conductor (24 AWG) cable 12 feet (3.66 meters) long. Cables can be extended to 200 feet (61 meters) maximum.
<b>M. Weight:</b>	1.5 lbs (.68 Kg)
<b>N. Dimensions:</b>	4.6 x 5.6 x 3.9 inches (116.84 x 142.24 x 99.06 mm)

## **FCC NOTICE**

This equipment has been tested and found to comply with the limits for a Class A digital device, pursuant to Part 15 of the FCC Rules. These limits are designed to provide reasonable protection against harmful interference when the equipment is operated in a commercial environment. This equipment is operated in a commercial environment. This equipment generates, uses, and can radiate radio frequency energy and, if not installed and used in accordance with the installation/maintenance instructions, may cause harmful interference to radio communications. Operation of this equipment in a residential area is likely to cause harmful interference in which case the user will be required to correct the interference at his own expense.

**CAUTION: Changes or modifications not expressly approved by HME could void the users authority to operate this equipment.**